



PT3636

Hi-sensitivity Unipolar Hall Switch

Applications

- Automotive Brake Pedal Position detection
- Proximity detection
- Weak magnets application
- Solid state switches

Features

- 3.8V to 24V wide operation voltage
- High accuracy unipolar switch
- Dynamic offset cancellation
- Open drain output
- Low thermal drift magnetic sensing

Ordering information

- PT3636-PA-T
Package(PA): UA or LH or LT
Temperature(T): A or K

Specifications

Absolute Maximum Ratings (Ta=25°C)

Parameter	Symbol	Conditions	Rating	Unit
Maximum supply voltage	V_{DDMAX}		28	V
Allowable power dissipation	P_D	TO-92(UA)	550 ^{*1}	mW
		SOT-23(LH)	300 ^{*1}	mW
		SOT-89(LT)	500 ^{*1}	mW
Operating temperature range	T_A	Suffix 'A'	-40~+150	°C
		Suffix 'K'	-40~+125	°C
Storage temperature range	T_S		-55~+150	°C
Max. output current	I_{OMAX}		50	mA

*1: On 50mm x 50mm x 1.6mm glass epoxy board

◆ All PROLIFIC products described or contained herein do not have specifications that can handle applications require extremely high levels of reliability, such as life-support systems, aircraft control systems, or other applications whose failure can be reasonably expected to result in serious physical and/or material damage. Consult with your PROLIFIC representative nearest you before using any PROLIFIC products described or contained herein in such applications.

◆ PROLIFIC assumes no responsibility for equipment failures that result from using products at values that exceed, even momentarily, the rated values (such as maximum ratings, operating condition ranges, or other parameters) listed in products specifications of any and all PROLIFIC products described or contained herein.

P/N: PT3636-XX-X

TO92-3L (UA)

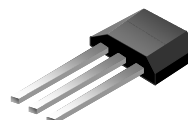

SOT23-3L (LH)

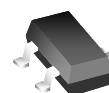

SOT89-3L (LT)

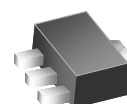

PROLIFIC TECHNOLOGY INC.

7F, No.48,Sec.3, Nan Kang Rd., Nan Kang, Taipei, 115, Taiwan.

Electrical Characteristics (T_A=+25°C, V_{DD}=12V)

Characteristic	Symbol	Test Condition	Min.	Typ.	Max.	Units
Supply Voltage	V _{DD}		3.8		24	V
Output Sink Voltage	V _{OL}	@ I _{OUT} =20mA		130	280	mV
Output Leakage Current	I _{OH}	Output switch off			0.1	uA
Output Clamp Voltage	V _{BV}			28	30	V
Supply Current	I _{DD}	Output open		4	6	mA

Magnetic Characteristics (T_A=+25°C, V_{DD}=12V)

Operate Point	B _{OP}		38	55	72	G
Release Point	B _{RP}		20	35	50	G
Hysteresis	B _{HYS}		15	20	27	G

Magnetic Characteristics (T_A=-40°C~150°C, V_{DD}=12V)

Operate Point	B _{OP}		34		77	G
Release Point	B _{RP}		18		54	G
Hysteresis	B _{HYS}		10		28	G

General Specifications

The PT3636 is a high sensitive unipolar Hall switch sensor. The built-in dynamic offset cancellation and temperature compensation of pre-amplifier stage achieves accuracy magnetic sensing. The wide supply voltage range is from 3.8V to 24V and the maximum output current is 50mA.

This Hall-effect sensor IC integrated the Hall plate, pre-amplifier with dynamic offset cancellation, hysteresis comparator and protection circuit in single chip. The architecture block diagram is shown in Fig. 1.

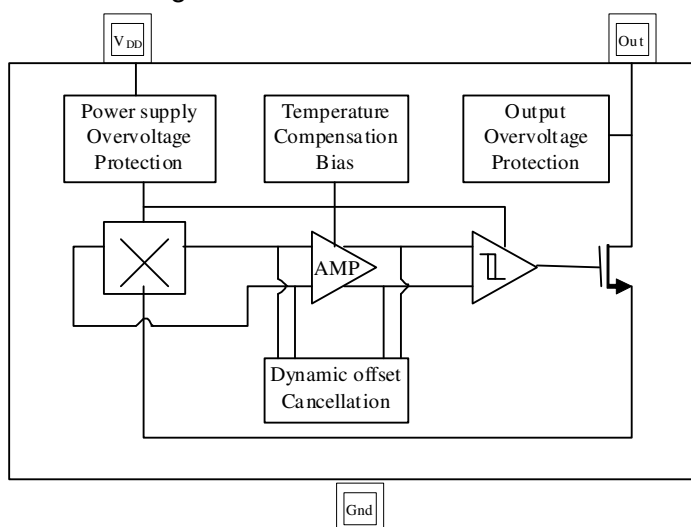
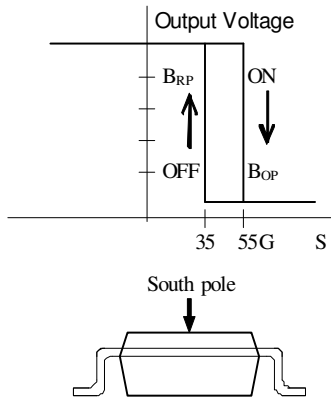
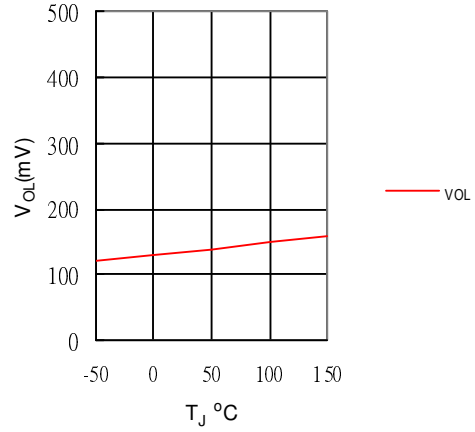
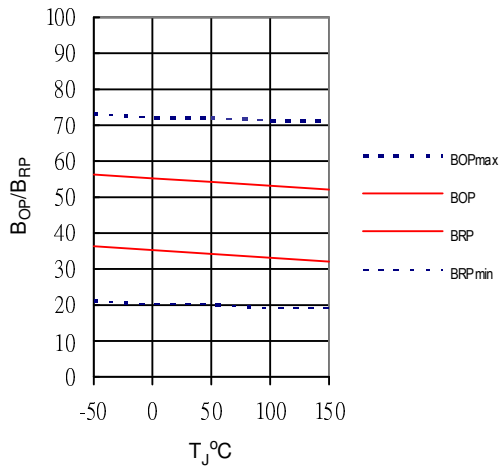
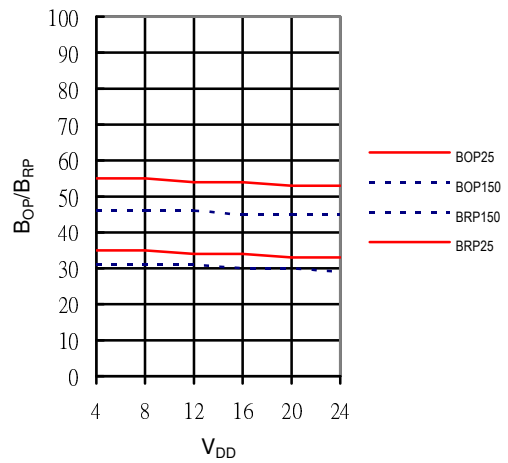

Fig. 1. Functional diagram

Magnetic Flux Density in G



Output sink voltage versus temperature

 B_{OP} , B_{RP} versus temperature

 B_{OP} , B_{RP} versus supply voltage

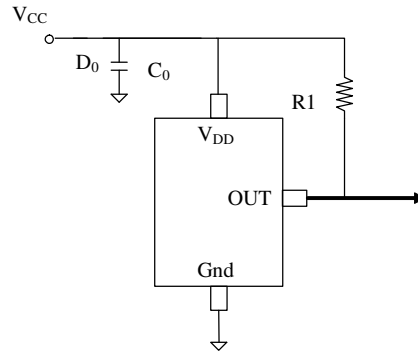
Application circuits



NOTE :

C0: decoupling capacitor 0.1uF(recommended)

R1: 1K~10Kohm (recommended)

Package Outline TO-92(UA)

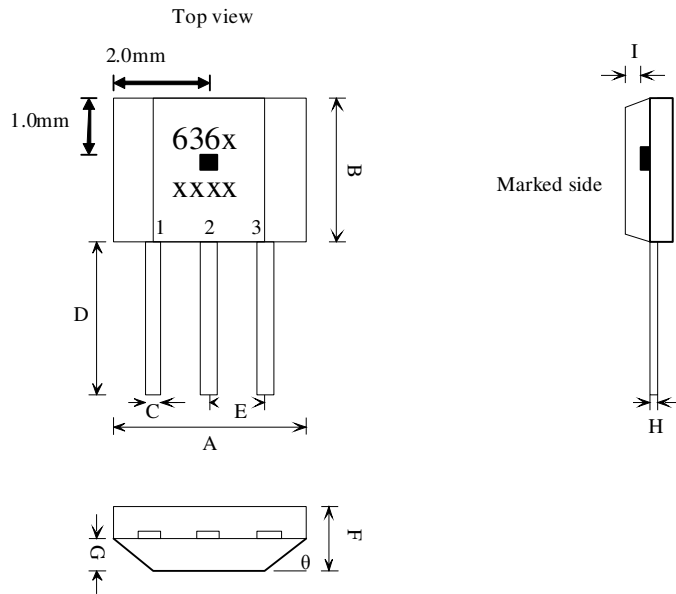

Marking:
 Part Number : 636 Temperature code : x
 Date Code : xx(Year) xx(Week)

1. VDD/DC power supply
 2. GND/DC ground
 3. OUT/output pin

SYMBOLS	DIMENSIONS IN MILLIMETERS(mm)		
	MIN	NOM	MAX
A	3.80	4.00	4.20
B	2.90	3.10	3.30
C	0.38	0.45	0.52
D	15.10	15.30	15.50
E	1.24	1.27	1.30
F	1.45	1.50	1.55
G	0.68	0.73	0.78
H	0.36	0.43	0.50
I	0.41	0.43	0.45
θ		45°	

Package Outline
SOT-23(LH)

Sensor Location

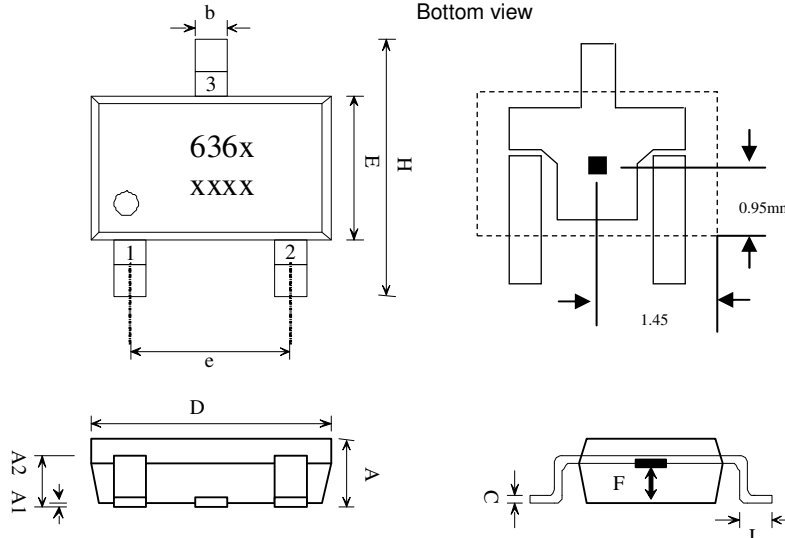

Marking:
Part Number : 636 Temperature code : x
Date Code : xx(Year) xx(Week)

- 1. VDD/DC power supply
- 2. OUT/output pin
- 3. GND/DC ground

SYMBOLS	DIMENSIONS IN MILLIMETERS(mm)		
	MIN	NOM	MAX
A	1.00	1.10	1.30
A1	0.00	-	0.10
A2	0.70	0.80	0.90
b	0.35	0.40	0.50
C	0.10	0.15	0.25
D	2.70	2.90	3.10
E	1.40	1.80	2.00
F	0.35	0.50	0.65
H	2.60	2.8	3.00
e	1.7	1.9	2.1
L	0.20	-	-

Package Outline
SOT-89(LT)

Sensor Location

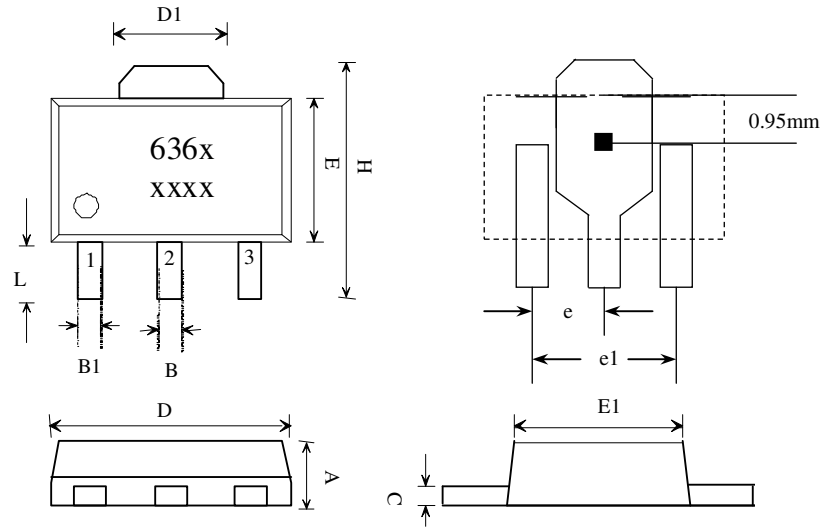

Marking:
Part Number : 636 Temperature code : x
Date Code : xx(Year) xx(Week)

1. VDD/DC power supply
2. GND/DC ground
3. OUT/output pin

SYMBOLS	DIMENSIONS IN MILLIMETERS(mm)		
	MIN	NOM	MAX
A	1.40	1.50	1.60
B	0.44	0.50	0.56
B1	0.36	0.42	0.48
C	0.35	0.40	0.44
D	4.40	4.50	4.60
D1	1.52	1.67	1.83
E	2.30	2.45	2.60
E1	2.13	2.21	2.29
e	-	1.50	-
e1	-	3.00	-
H	3.94	4.10	4.25
L	0.89	1.05	1.20